

Araç Tipi / Vehicle Type:

VİDANJÖR VE KOMBİNE KANAL AÇMA ARAÇLARI
USAGE FOR CESSPIT EMPTIERS, FOR CLEANING COMBINATION MACHINES

Şanzıman Tipi / Gearbox Type:

Ürün Kodu / Product Code:

UARA.2400

ÜRÜN GÖRÜNÜMLERİ / PRODUCTS VIEW

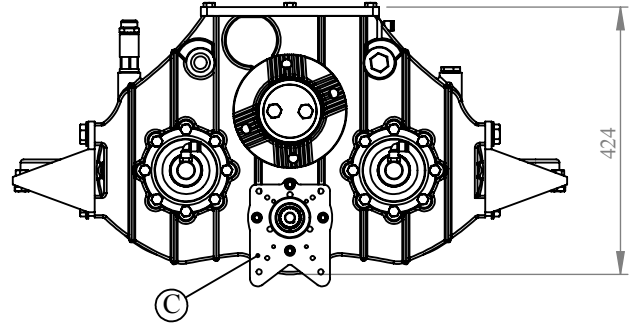
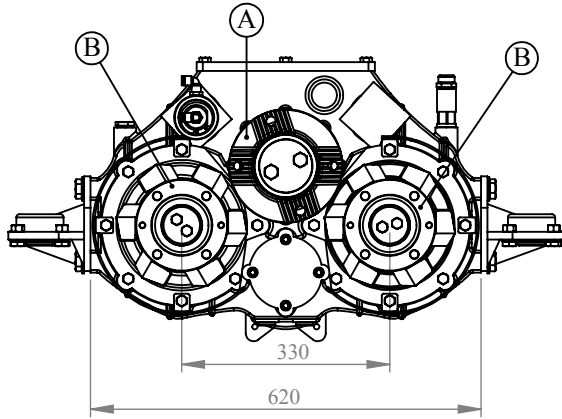
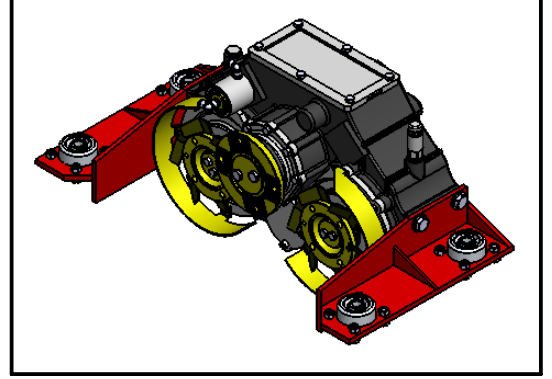
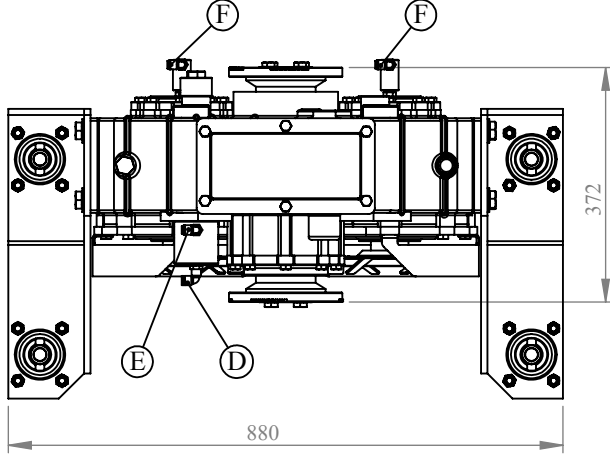

OPSİYONLAR / OPTIONS

A : DIN 150 (4 D. Taramalı), DIN180 (4 D. Taramalı), DIN180 (8 D.)
B : DIN140 (4 Delikli Taramasız)
C : Pompa Çıkışı: 1P1, 2P1, Dişli Pompa
D : Hava Girişi R1/4" (Differansiyel Çıkışı Devrede)
E : Hava Girişi R1/4" (Differansiyel Çıkışı Devre Dışı)
F : Hava Girişi R1/4" (Yan Çıkışlar Devrede)

A : DIN 150(4 H. Cross Hatching),DIN180(4 H. Cross Hatching),DIN180(8 H.)
B : DIN140 (4 Holes)
C : Pump Output: 1P1, 2P1, Gear Pump
D : Air Inlet R1/4" (Rear Axle Output Engage)
E : Air Inlet R1/4" (Rear Axle Output Disengage)
F : Air Inlet R1/4" (Outputs Engage)

TEKNİK BİLGİ / TECHNICAL DATA

Güç (Kw) (Power) 1000 Dev./Dak.	Maksimum Tork (Max. Torque) Nm Kgm		Çevrim Oranı (Ratio)	Bağlantı Şekli (Mounting Side)	Kumanda Kontrol (Control Type)
115	1080	110	1/1.25	SAFT/SHAFT	HAVALI/PNEUMATIC
				Ağırlık (Kg) (Weight)	Dönüş Yönü (Rotation Sense)
				195	SAĞ/CLOCKWISE(CW)

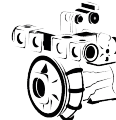

DUPAMP - FIRE PUMP WORLD

1. ASD OSB Erkunt Cad. No:6
06935 Sincan - Ankara - TÜRKİYE