

Araç Tipi / Vehicle Type:  
İTFAİYE ARAÇLARI-YOL BAKIM ARAÇLARI  
FOR FIRE FIGHTING VEHICLES-FOR ROAD SERVICE VEHICLES

Şanzıman Tipi / Gearbox Type:

Ürün Kodu :/ Product Code:

**UARA.806**

## ÜRÜN GÖRÜNÜMLERİ / PRODUCTS VIEW

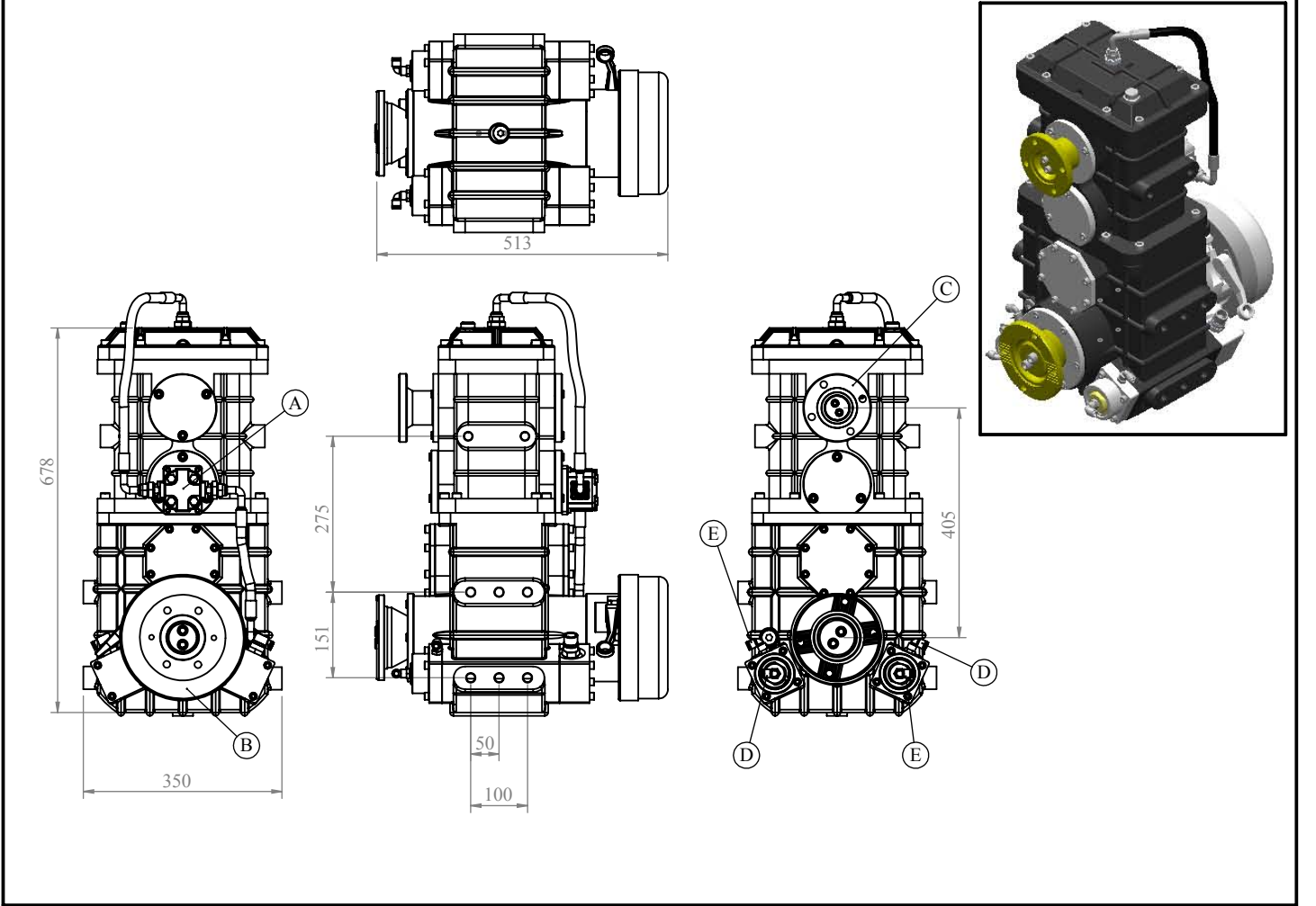

## OPSİYONLAR / OPTIONS

**A : Dişli Pompa**  
**B : Fren Balata Sistemi (Mitsubishi-Hyundai-İsuzu-Hino)**  
**C : Flanş, DIN 100 ve DIN 120**  
**D : Hava Girişi R1/4" (Devreye Alma)**  
**E : Hava Girişi R1/4" (Devreden Çıkartma)**

**A : Gear Pump**  
**B : Hand Brake System (Mitsubishi-Hyundai-Isuzu-Hino)**  
**C : Flange, DIN 100 and DIN 120**  
**D : Air Inlet R1/4" (Engage)**  
**E : Air Inlet R1/4" (Disengage)**

## TEKNİK BİLGİ / TECHNICAL DATA

Güç (Kw) (Power) 1000 Dev./Dak.	Maksimum Tork (Max. Torque) Nm Kgm		Çevrim Oranı (Ratio)	Bağlantı Şekli (Mounting Side)	Kumanda Kontrol (Control Type)
135	1275	130	1/1.7	ŞAFT/SHAFT	HAVALI/PNEUMATIC
				Ağırlık (Kg) (Weight)	Dönüş Yönü (Rotation Sense)
				176	SAĞ/CLOCKWISE(CW)



**DUPAMP - FIRE PUMP WORLD**  
1. ASD OSB Erkunt Cad. No:6  
06935 Sincan - Ankara - TÜRKİYE